

APC-3568/3568J

Hardware UserGuide



Powered by:

Geniatech

Contents

1 Introduction	3
1.1 Product appearance	4
1.2 Other Overview.....	5
2 What's in the Developer Board	5
3 Getting started	6
3.1 Prerequisites	6
3.2 Starting the board for the first time	6
4. DS-3568 Overview	7
4.1 Product Diagram	7
4.2 Internal Connectors, Headers & Jumpers	9
4.2.1 USB2.0-1 (J7).....	10
4.2.2 USB2.0-2 (J6).....	11
4.2.3 RS485&CAN (J19).....	11
4.2.4 Fault LED (LED3).....	12
4.2.5 Power LED (LED2)	12
4.2.6 SATA Power (J5).....	13
4.2.8 Speaker (J10).....	14
4.2.9 I2C/TP (J15).....	14
4.2.10 LCD Type Options (J3)	15
4.2.11 LVDS (J11)	15
4.2.12 LCD Voltage (J12)	16
4.2.13 RTC battery port (J18).....	17
4.2.14 Debug (J2).....	17
4.2.15 RS232/DB9 (CN3/CN4/CN5/CN6)	18

4.2.16 Backlight (J16).....	18
4.2.17 GPIO (J20)	19
4.2.18 eDP_Voltage (J13).....	20
4.2.19 eDP (J14).....	20
4.3 Precautions for use.....	21

1 Introduction

APC-3568 is an Android Customized Board with following new features:

- (I) Quad core ARM Cortex-A55 CPU up to @ 2.0GHz
- (II) ARM Mali-G52 GPU, Support OpenGL ES1.1/2.0/3.2, OpenCL2.0 and Vulkan 1.1
- (III) NPU: Neural network acceleration engine with processing performance up to 0.8 TOPS
- (IV) Support Android 11.0 / Linux Debian/Ubuntu OS
- (V) Support 2GB/4GB/8GB LPDDR4, 8~128GB eMMC, External expansion TF/SATA3.0/USB storage
- (VI) Dual Ethernet 10/100/1000M
- (VII) IEEE 802.11b/g/n/ac (2.4G&5G) +BT4.2 (BT5.0 optional)
- (VIII) Support Mini PCIE LTE(Modules such as Quectel / Fibocom)
- (IX) 1 * HDMI Out, 1 * LVDS, 1 * eDP, support multi-screen simultaneous display, multi-screen different display, multi-screen rotation splicing, multi-channel video source simultaneous decoding, etc. Display method
- (X) Support 4 * RS232(DB9) + 1 * RS485 + 1 * Can + 2 * GPIO industrial control bus
- (XI) 2 * USB3.0 + 4 * USB2.0 (Two built-in)
- (XII) Support hardware WDT & RTC + 1*SATA3.0 + 1*Speaker (Max: 2*5W8Ω)
- (XIII) Support USB and I2C TP
- (XIV) Support wide voltage 9~24V power input, standard EMC and ESD protection design
- (XV) Specially designed for smart express cabinet, smart commercial display, smart vending machine, digital signage, smart home, etc.
- (XVI) Operation temperature: 0~60℃ (APC-3568) , -40~85℃ (APC-3568J) .

1.1 Product appearance

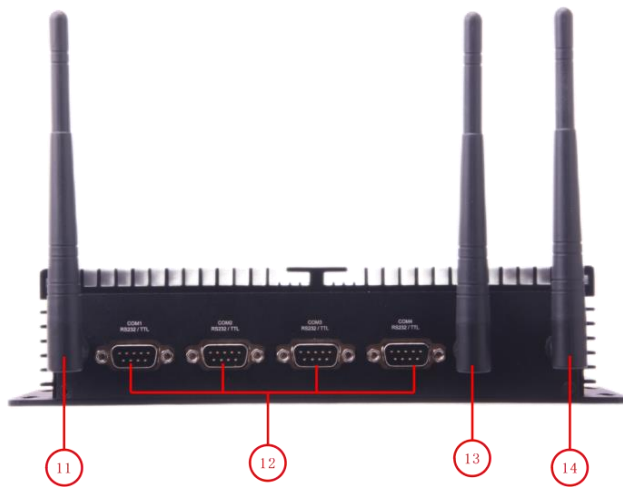
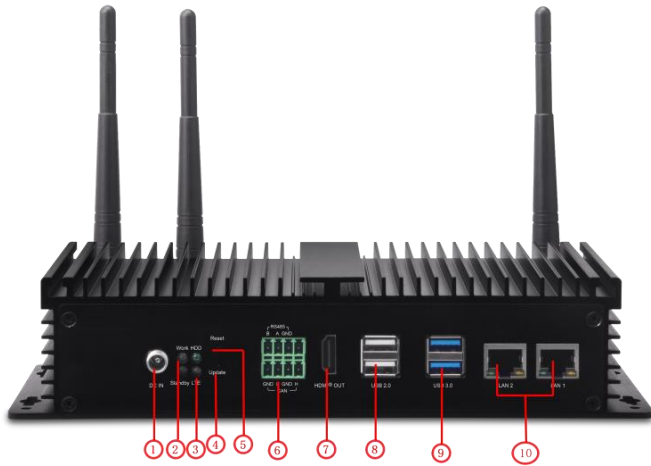

No...	Name	Description
1	DC In	1*(DCΦ5.5mm / φ2.1mm)
2	Power LED	2 * LED(Red/Green)
3	Fault LED	2 * LED(Red/Blues)
4	Key (Update)	1 * Switch
5	Key (Reset)	1 * Switch
6	RS485/CAN	2*4Pin 3.81mm
7	HDMI	HDMI OUT
8	USB2.0	2*USB2.0-Type A
9	USB3.0	2*USB2.0-Type A
10	LAN	2*RJ45(1000M Ethernet)
11	LTE	1 * SMA
12	COM (RS232/TTL)	4*DB9
13	WIFI/BT ANT	1 * SMA
14	LTE	1 * SMA

1.2 Other Overview



No...	Name	Description
1	Micro SD	1 * Micro SD
2	Micro SIM	1* Micro SIM

2 What's in the Developer Board

The Developer Board contains one DS-3568/DS-3568J.

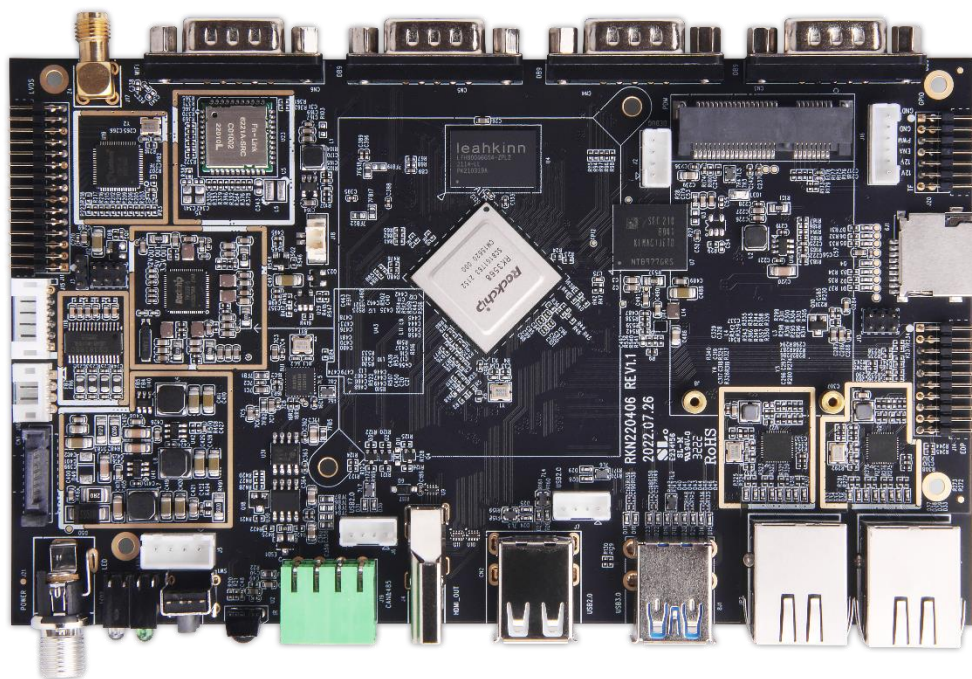

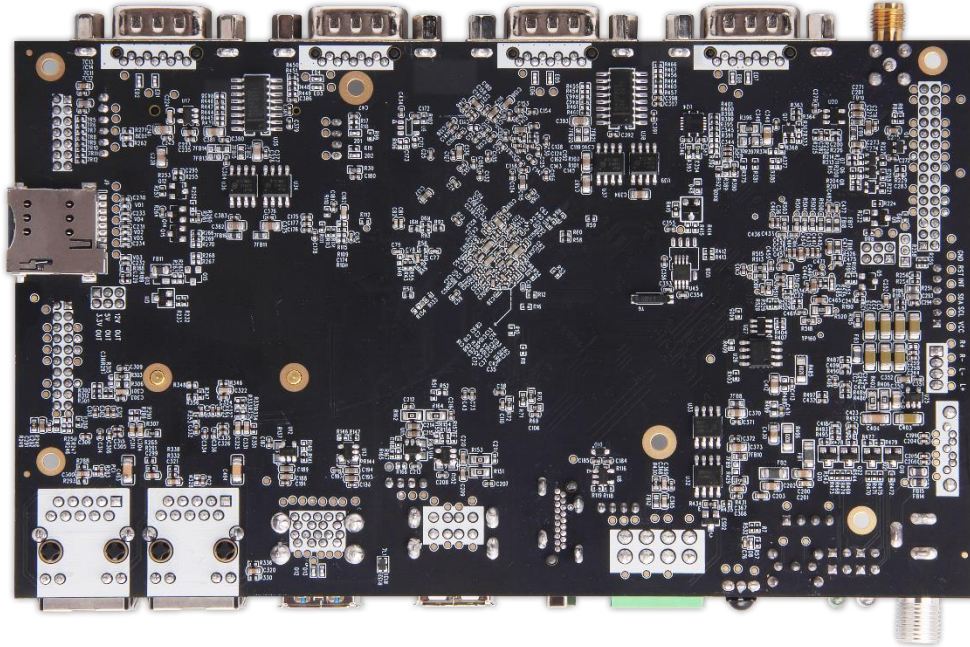

3 Getting started

3.1 Prerequisites

Before you power up your APC3568/APC3568J for the first time you will need the following:

- APC 3568/APC3568J
- A APC3568/APC3568J board compliant power supply (sold separately by Geniatech).
- A APC3568/APC3568J board compliant IR remote (sold separately by Geniatech).
- A LVDS or eDP LCD Monitor that supports a resolution of 2560x1600@60Hz.
- LVDS-LVDS cable or eDP-eDP cable to connect the board to the LCD.
- A computer keyboard/mouse with USB interface.

3.2 Starting the board for the first time

To start the board, follow these simple steps:

- step 1. Connect the LVDS / eDP cable to the APC3568/APC3568J connector (marked) and to the LCD Monitor.
- step 2. Connect the keyboard to the boards USB connector marked or connect the mouse to the USB connector marked. (It doesn't matter which order you connect it in. You can also connect via an external USB Hub.)
- step 3. Connect the power supply to power connector marked.

Power on (Plug power adapter), toggle the power switch, then the board will boot up and you will see the boot up logo with Android.

Please note that the first boot takes several minutes due to Androids initialization. Subsequent boot times should be faster.

4. APC3568/APC3568J Overview

4.1 Product Diagram

TOP View:

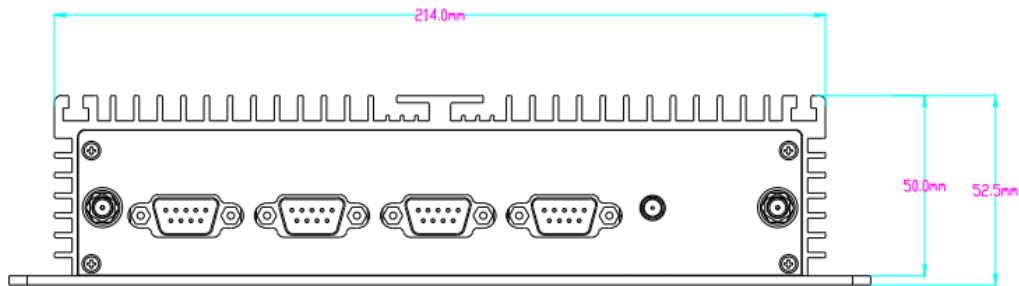
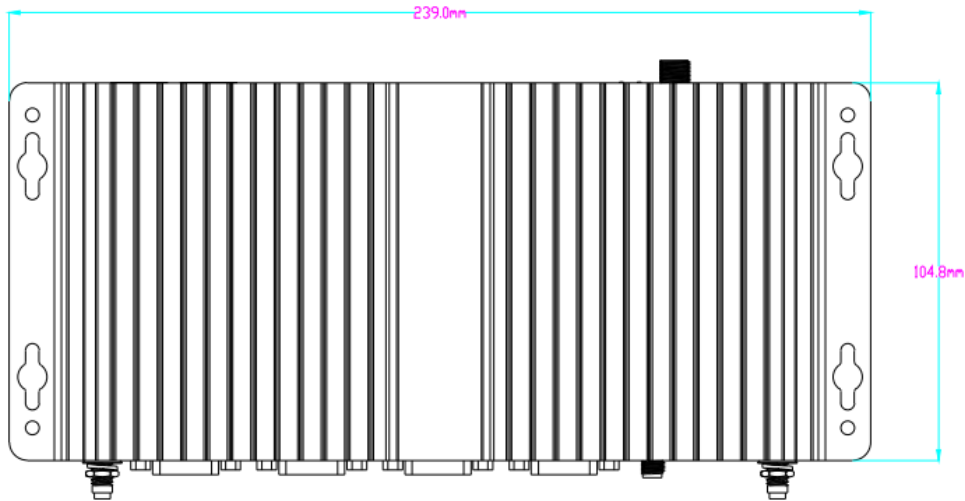

4.2 Internal Connectors, Headers & Jumpers

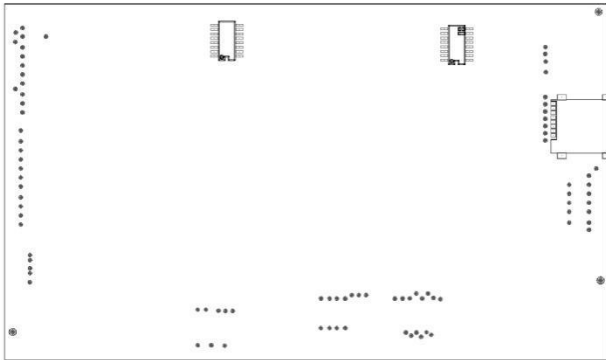
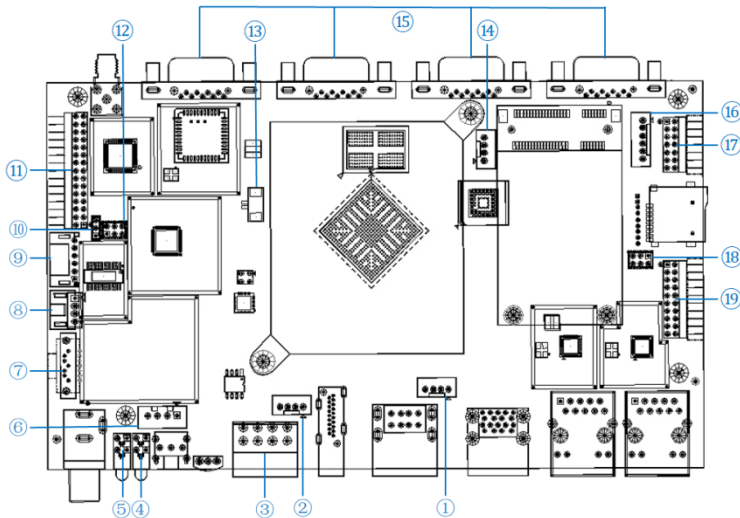

No	Name	Description
1	USB2.0-1	1*4Pin2.0mm
2	USB2.0-2	1*4Pin2.0mm
3	RS485&CAN	1*(2*4pin 3.81mm)
4	Fault LED	2*LED (Red+Green)
5	Power LED	1*LED (Red+Blue)
6	SATA Power	1*4Pin2.54mm
7	SATA3.0	1*SATA3.0
8	SPK	1*4Pin2.0mm
9	I2C(TP)	1*6Pin2.0mm
10	LCD Type Options	1*3pin 2.0mm
11	LVDS	1*(2*15Pin2.0mm)
12	LVDS_Voltage	1*(3*2pin 2.0mm)
13	RTC battery port	1*2Pin1.25mm
14	Debug	1*4pin 2.0mm
15	RS232	4*DB9
16	Backlight	1*6Pin2.0mm
17	GPIO	1*(2*7Pin2.0mm)
18	eDP_Voltage	1*(3*2pin 2.0mm)
19	eDP	1*(2*10Pin2.0mm)

4.2.1 USB2.0-1 (J7)

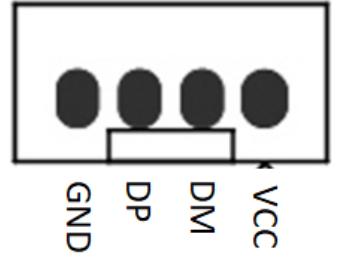
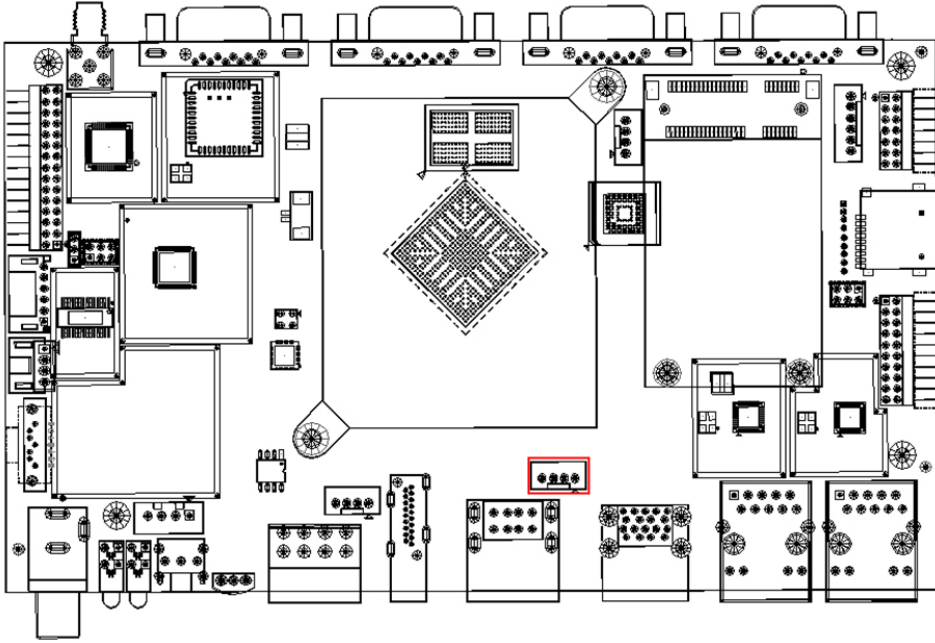

4.2.2 USB2.0-2 (J6)

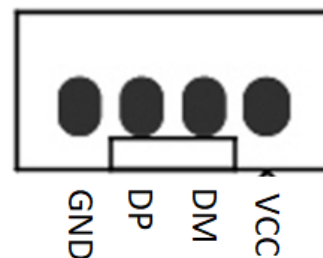
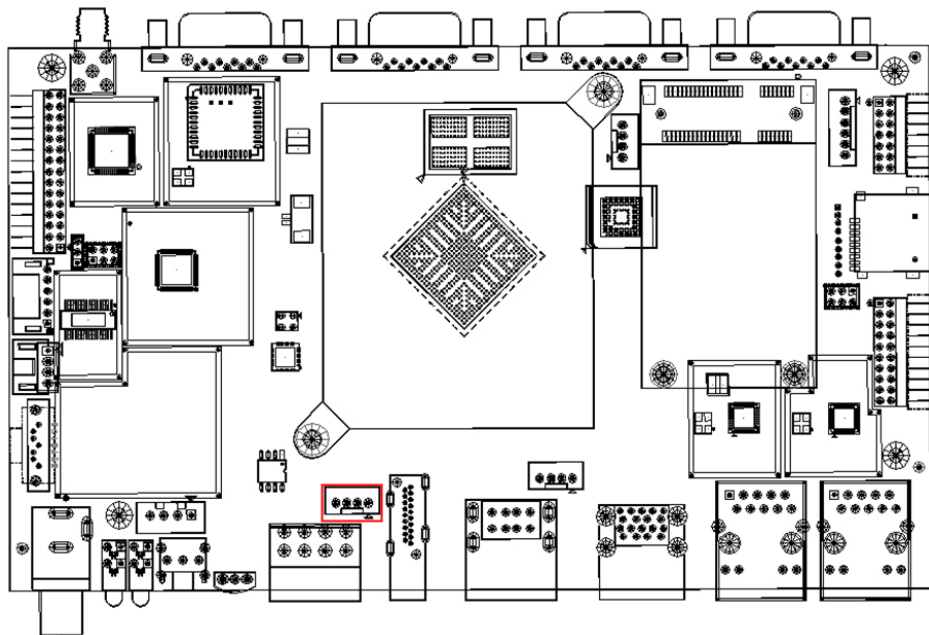

4.2.3 RS485&CAN (J19)

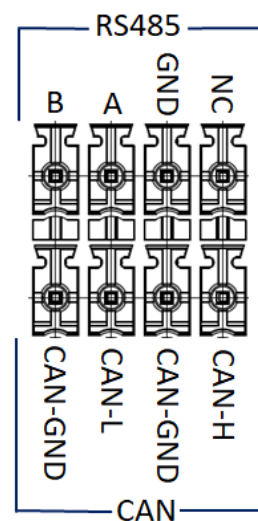
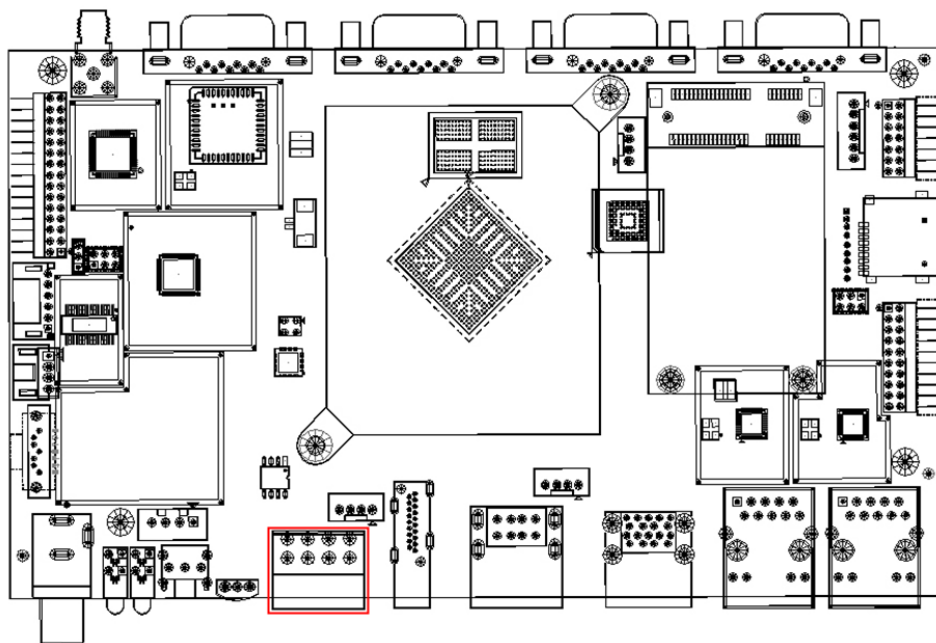

4.2.4 Fault LED (LED3)

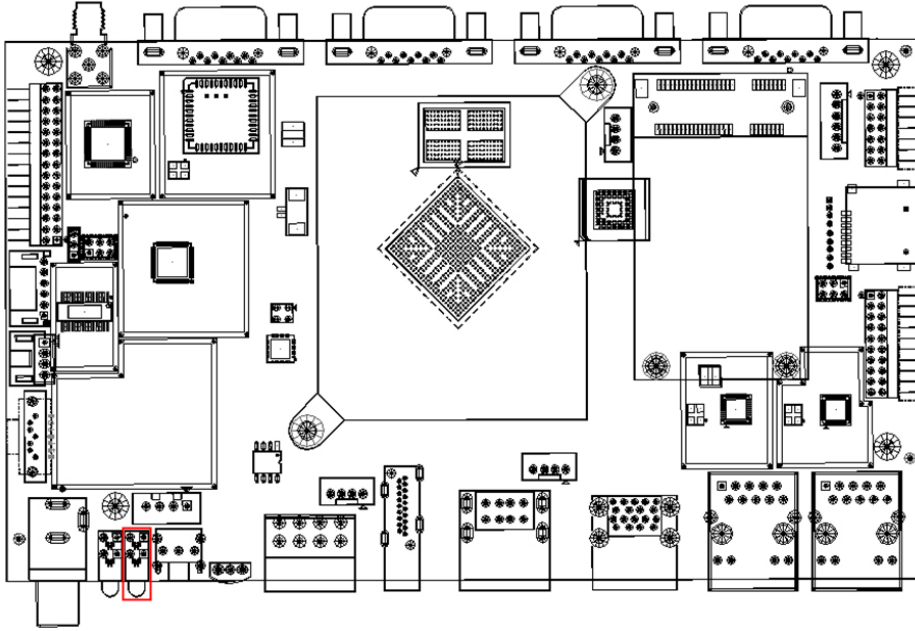

Red (HDD): [off: not connected];
[steady: connected]; [flashing: data exchange]
Blue (LTE): [off: not connected];
[steady: connected]; [flashing: data exchange]

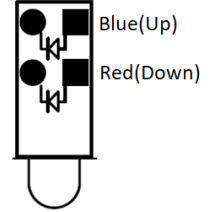

4.2.5 Power LED (LED2)

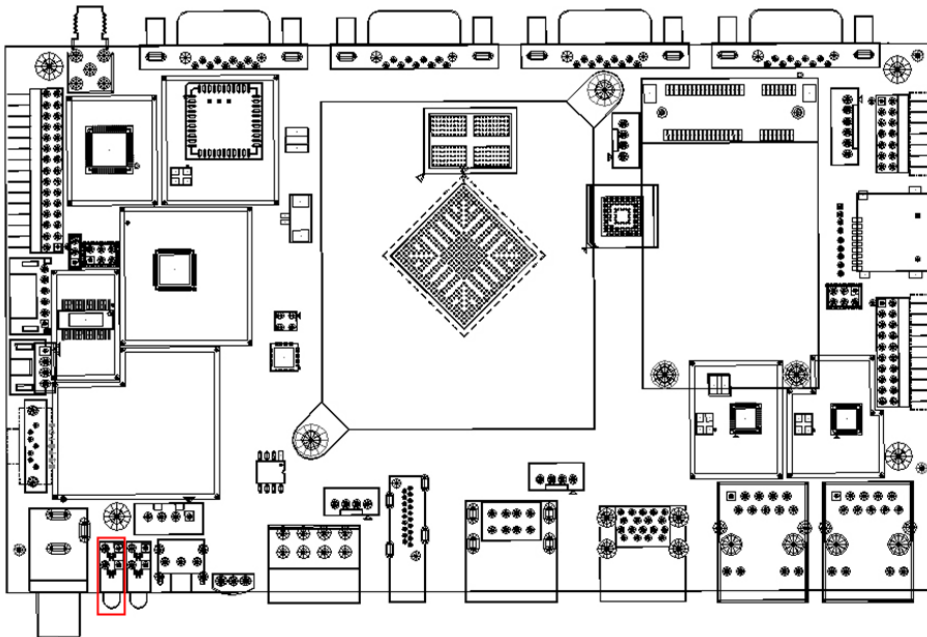

Green:Work
Red:Off/Standby

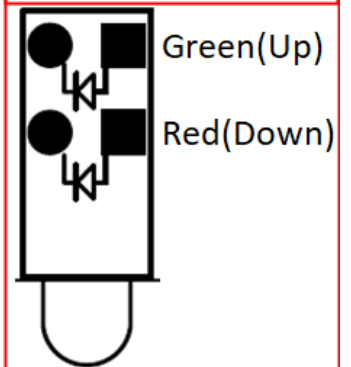

4.2.6 SATA Power (J5)

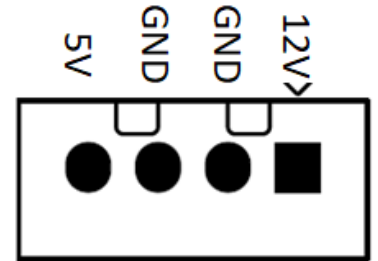
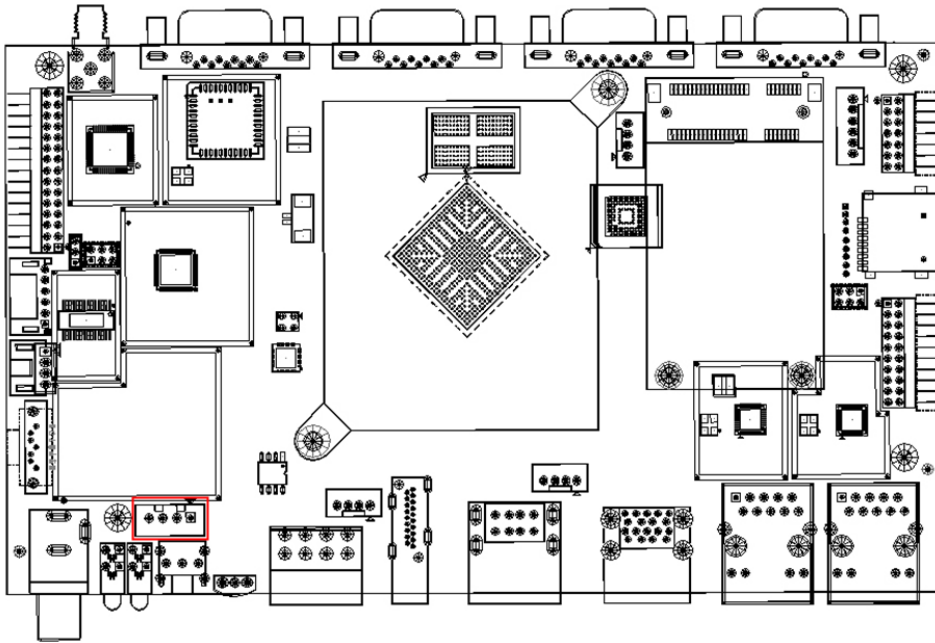

4.2.7 SATA3.0 (CN1)

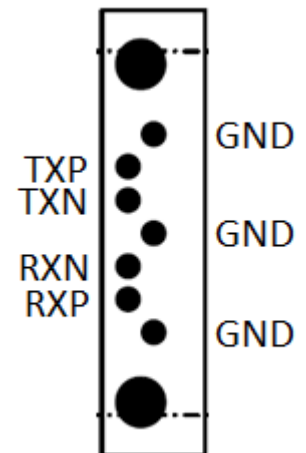
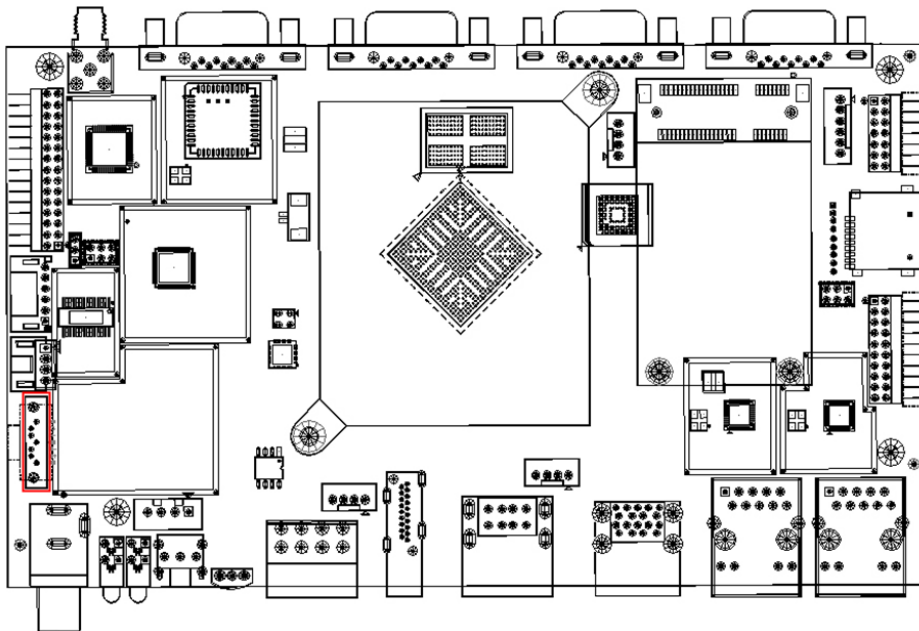

4.2.8 Speaker (J10)

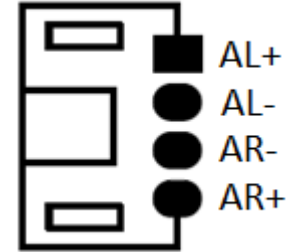
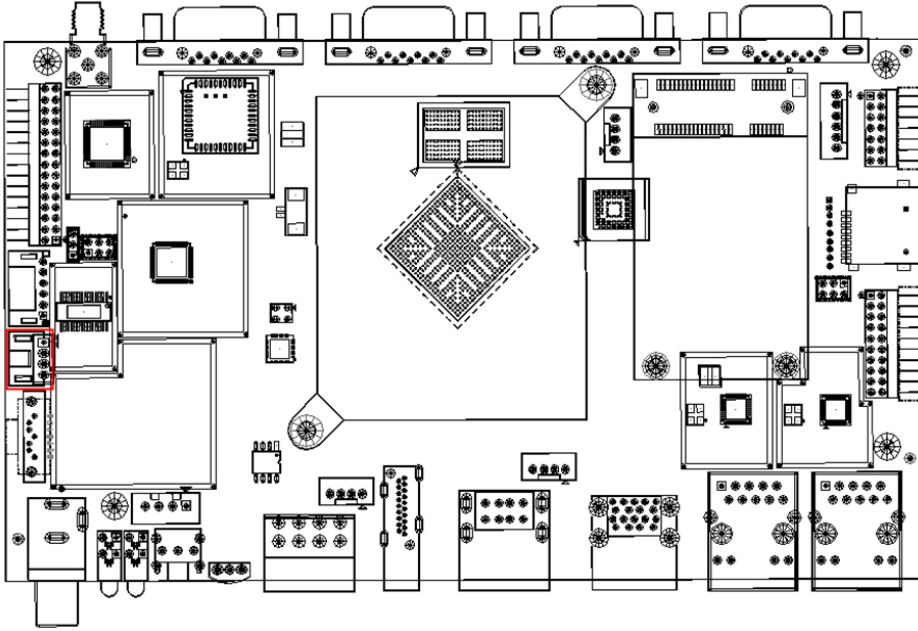

4.2.9 I2C/TP (J15)

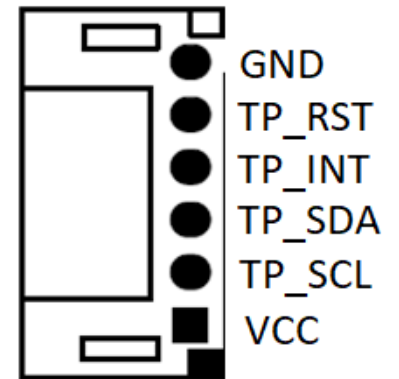
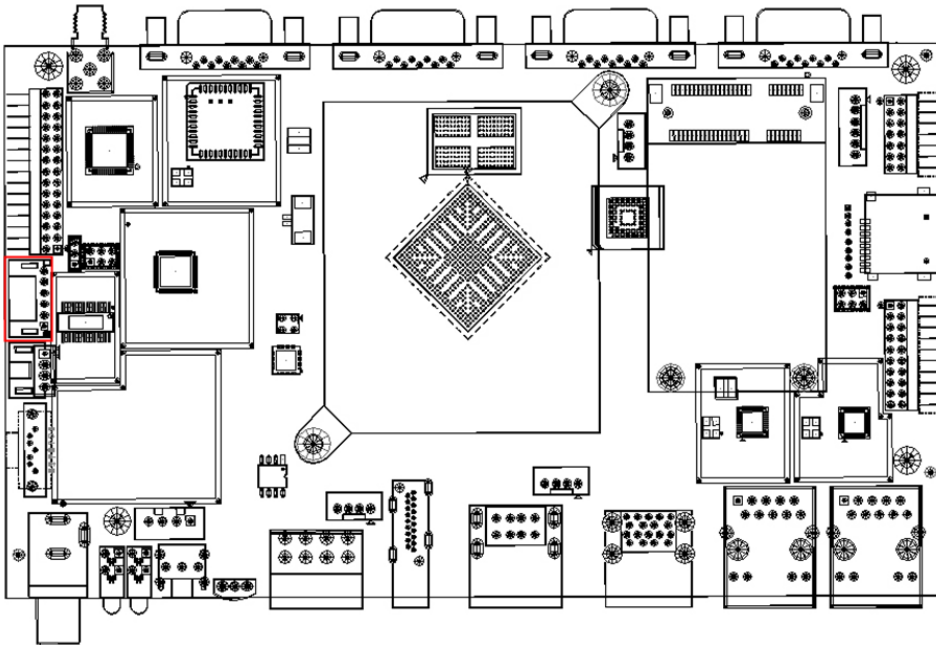

4.2.10 LCD Type Options (J3)

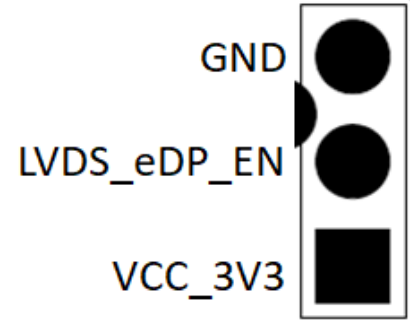
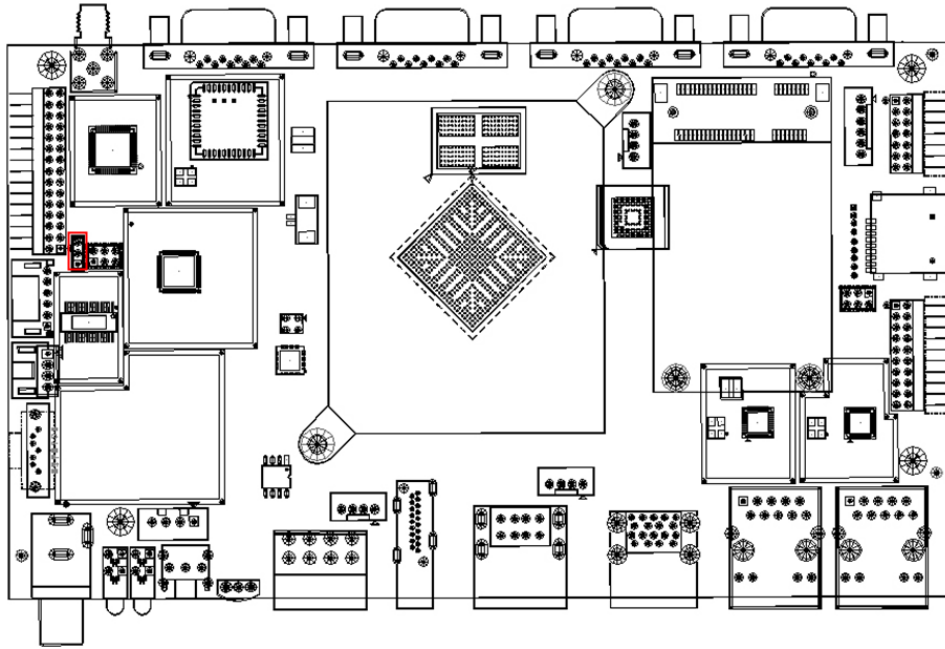

4.2.11 LVDS (J11)

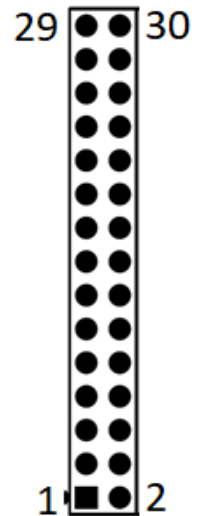
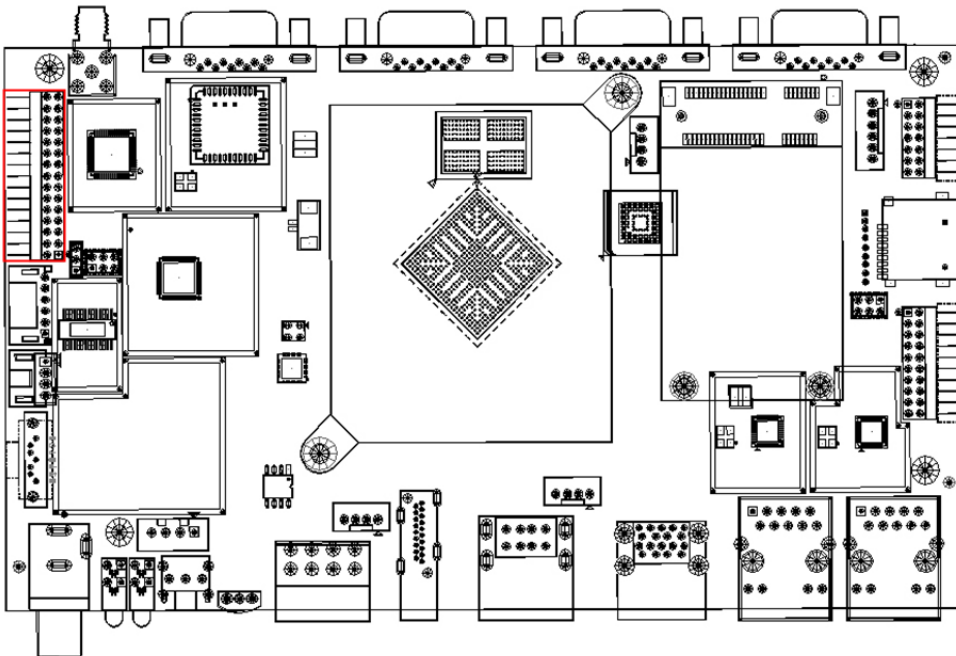

Pin Name	Pin No.	Pin No.	Pin Name
VCC_PANEL	1	2	VCC_PANEL
VCC_PANEL	3	4	GND
GND	5	6	GND
LVDS_A0_N	7	8	LVDS_A0_P
LVDS_A1_N	9	10	LVDS_A1_P
LVDS_A2_N	11	12	LVDS_A2_P
GND	13	14	GND
LVDS_ACLK_N	15	16	LVDS_ACLK_P
LVDS_A3_N	17	18	LVDS_A3_P
LVDS_B0_N	19	20	LVDS_B0_P
LVDS_B1_N	21	22	LVDS_B1_P
LVDS_B2_N	23	24	LVDS_B2_P
GND	25	26	GND
LVDS_BCLK_N	27	28	LVDS_BCLK_P
LVDS_B3_N	29	30	LVDS_B3_P

4.2.12 LCD Voltage (J12)

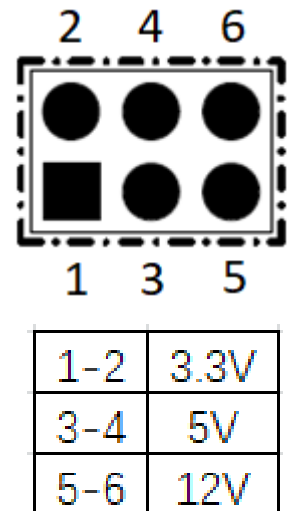
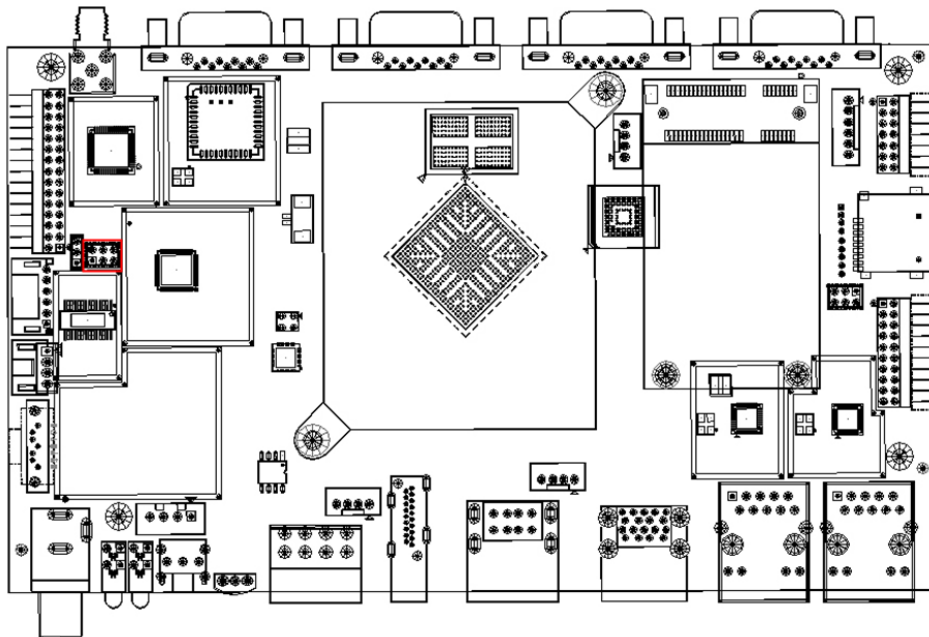

4.2.13 RTC battery port (J18)

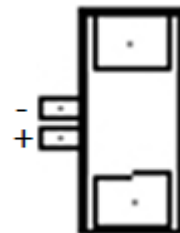
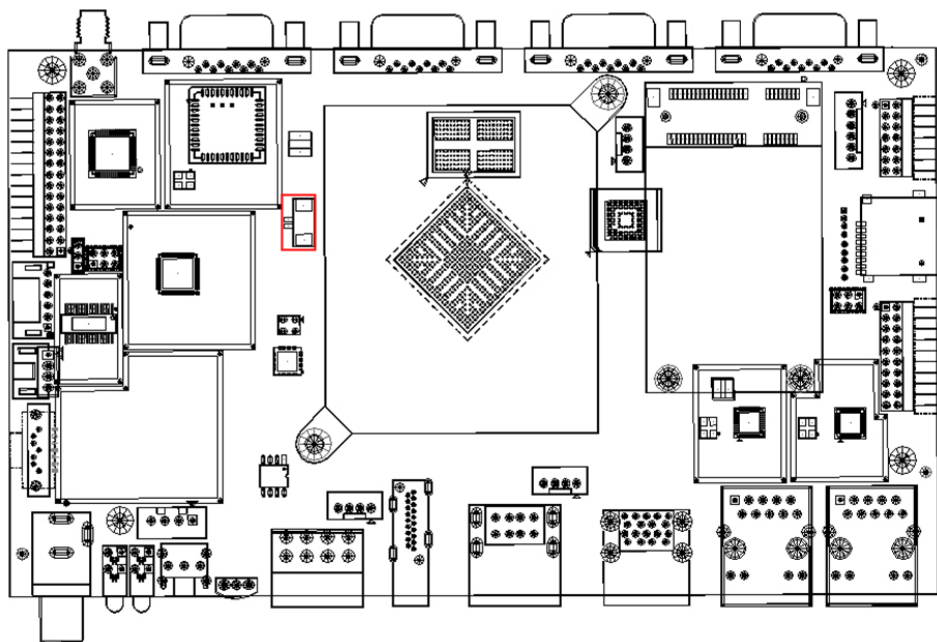

4.2.14 Debug (J2)

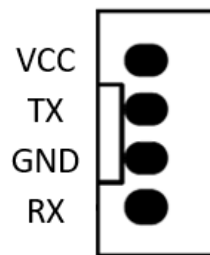
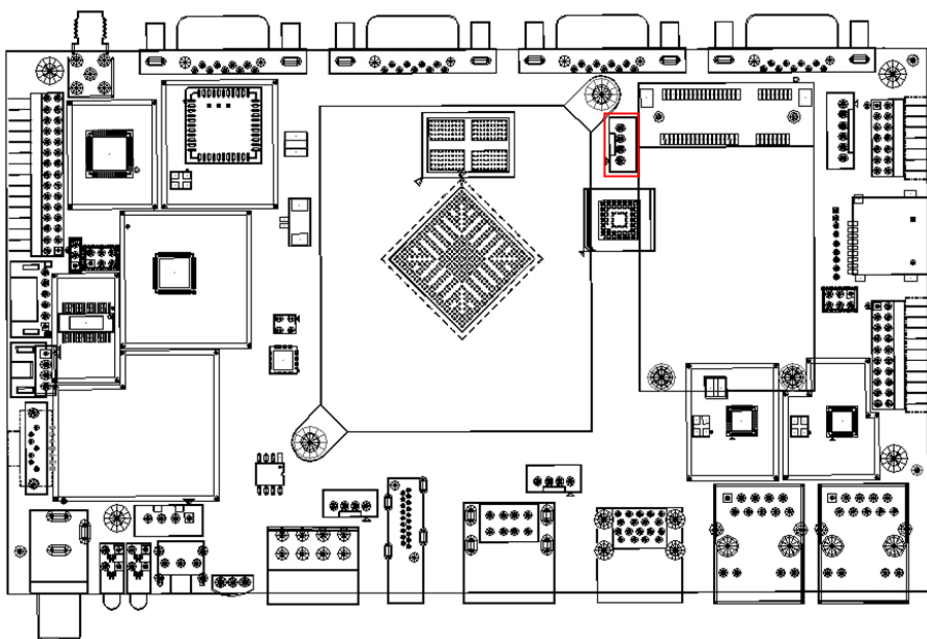

4.2.15 RS232/DB9 (CN3/CN4/CN5/CN6)

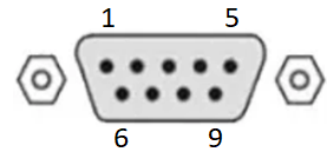
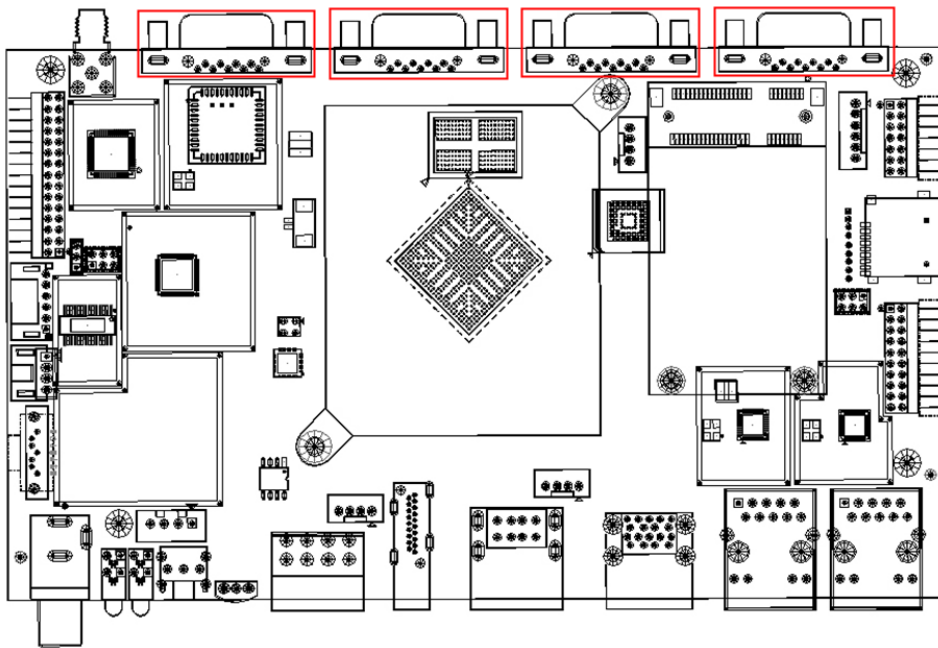

Pin No.	Pin Define
1	NC
2	RX
3	TX
4	NC
5	GND
6	NC
7	NC
8	NC
9	NC

4.2.16 Backlight (J16)

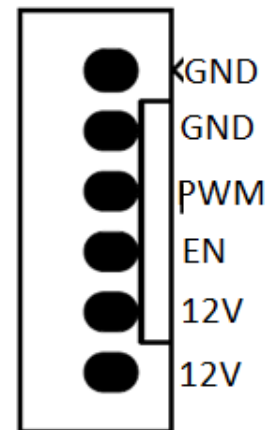
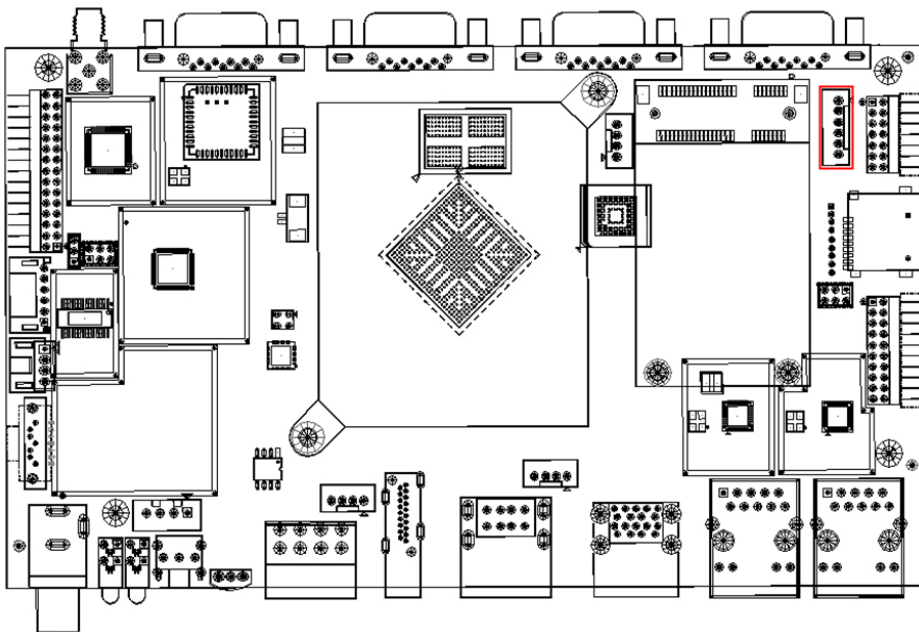

4.2.17 GPIO (J20)

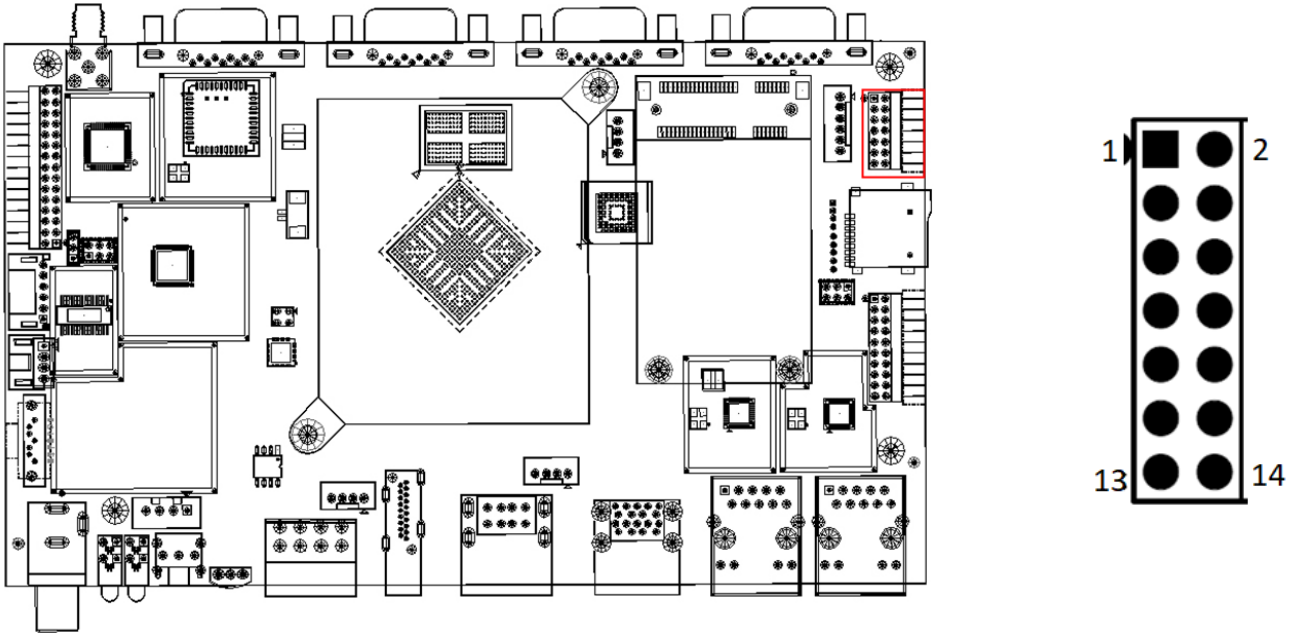

Pin Name	Pin No.	Pin No.	Pin Name
VCC_3V3	1	2	VCC_5V0
GND	3	4	GND
UART9_TX_M1	5	6	I2C2_SDA_M1
UART9_RX_M1	7	8	I2C2_SCL_M1
GPIO0_D3	9	10	I2C3_SDA_UART_RX
GPIO4_C4	11	12	I2C3_SCL_UART_TX
GND	13	14	GND

4.2.18 eDP_Voltage (J13)

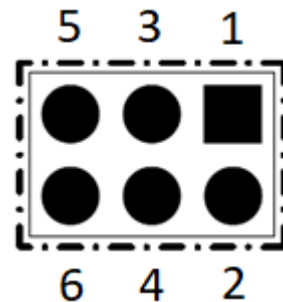
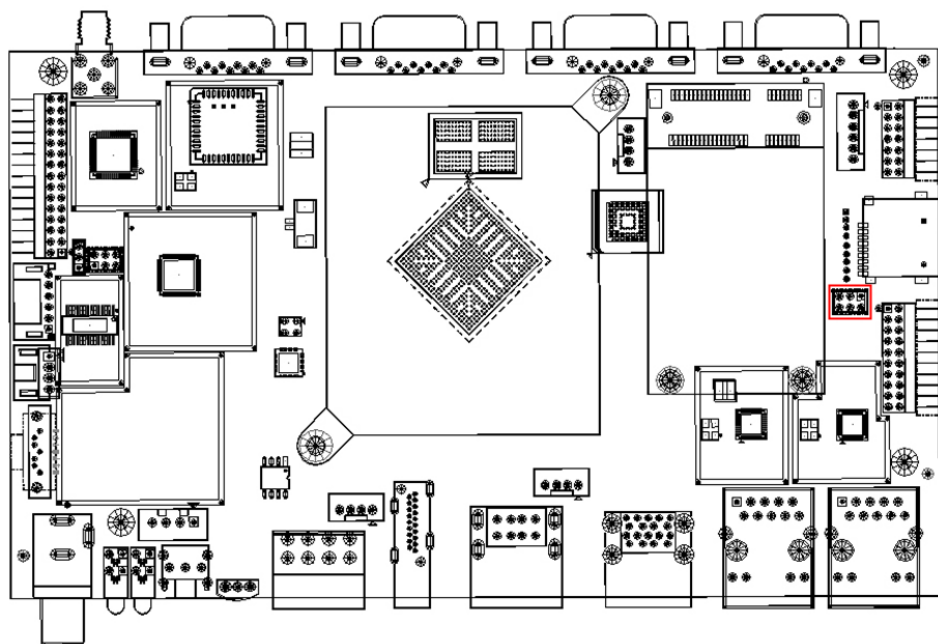

1-2	3.3V
3-4	5V
5-6	12V

4.2.19 eDP (J14)

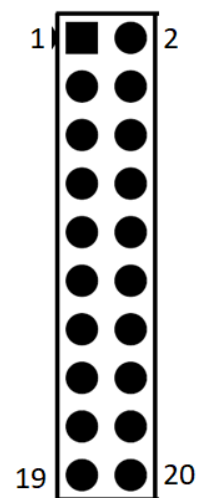
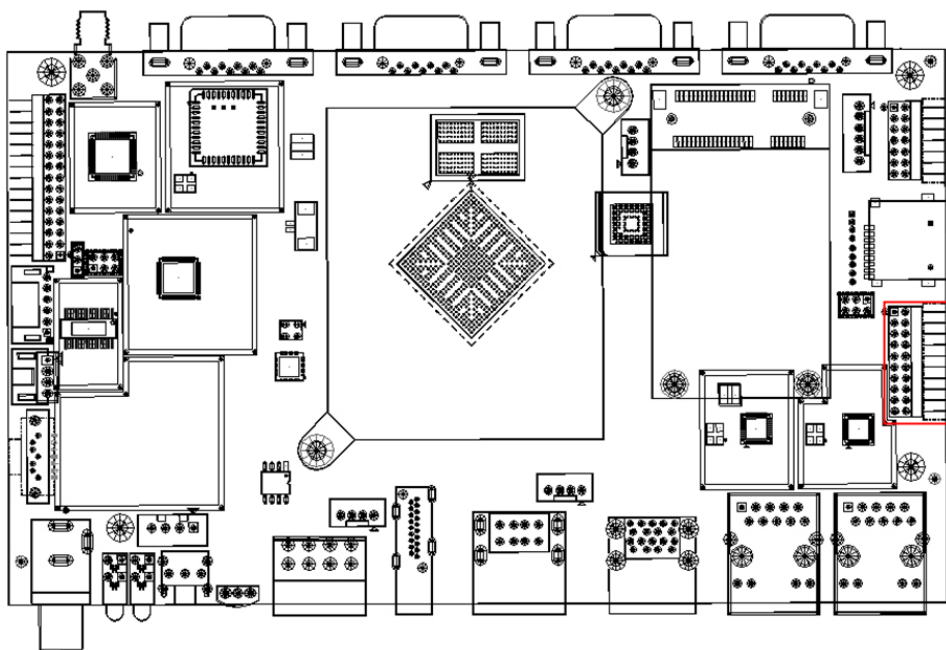

Pin Define	Pin No.	Pin No.	Pin Define
VCC_EDP	1	2	VCC_EDP
GND	3	4	GND
EDP_TX_D0N	5	6	EDP_TX_D0P
EDP_TX_D1N	7	8	EDP_TX_D1P
EDP_TX_D2N	9	10	EDP_TX_D2P
EDP_TX_D3N	11	12	EDP_TX_D3P
GND	13	14	GND
EDP_TX_AUXN	15	16	EDP_TX_AUXP
GND	17	18	GND
VCC3V3/GND	19	20	EDP_HPD

4.3 Precautions for use

1. Relative humidity: 10% ~ 95% .
2. Storage temperature: -20 ~ 85°C (if Extended commercial -40~100°C)
3. Do not squeeze, distort or disassemble the board.
4. Keep the board away from static electricity .
5. Keep the board away from water and other liquid.
6. Clean the board with soft and clean dry cloth when it's dirty.
7. Don't use long connect wires which may affect performance and image quality.